

Technical perfection and top design

**Kränzle**<sup>®</sup>  
HOCHDRUCKREINIGER

w w w . k r a n z l e . c o m

# Operating manual Power sweeper 2+2



Read and conform safety instructions before use!



# ***Description***

## Dear Customer

Congratulations on your new sweeper!

For your convenience, a description of the machine is provided on the following pages.

### Technical specifications

Method of operation:	2- roller hasp principle
Working width:	800 mm
Weight:	17 kg
Container capacity:	40 litres
Brushes:	heavy duty polypropylene
Seeping rate:	approx. 3000 m <sup>2</sup> / hr

The machine is fully recyclable. It is made completely of polypropylene „PP“ and natural rubber. The brush rollers are made of wood.

The machine is PVC - FREE and one hundred percent.....

... made by

**kränzle**<sup>®</sup>

The sweeper is designed for use on a level surface.

With the side brushes pressed, you can push the machine easily over the surface to be cleaned. This should be done at normal walking speed (approx 3 km/hr). The seeping rate depends on the speed the brush rollers rotate, and this in turn depends on the speed the machine is pushed. The pushing force required is between 3 and 3,5 kg, depending on the surface,

If you wish to move the machine for longer distances without sweeping, pull it backwards so that the sweeping function is disabled by the built-in free-wheel feature.

# Assembly for side brushes and push handle

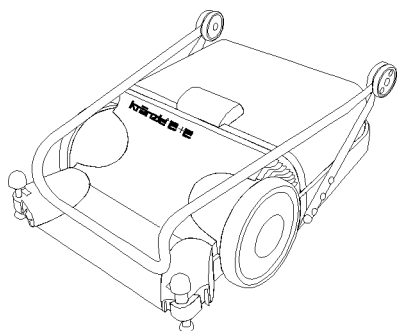

Place the machine on the ground

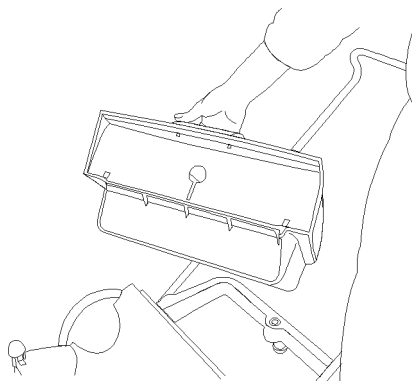

.. and lift it out

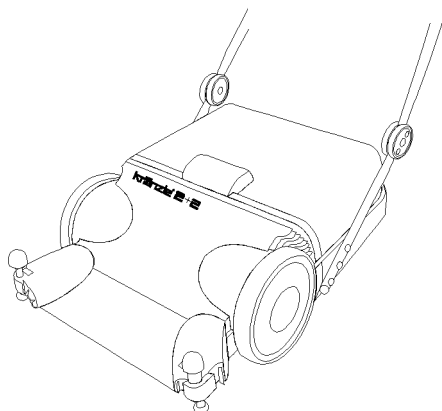

Pull the push handle upwards

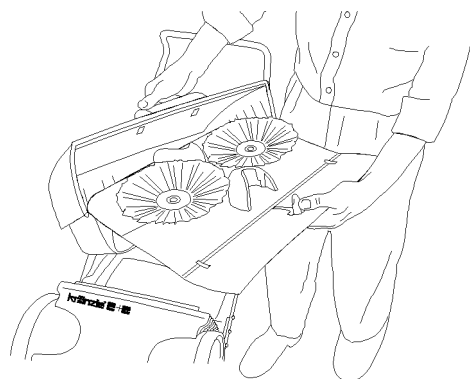

Pull the cover of the interior.

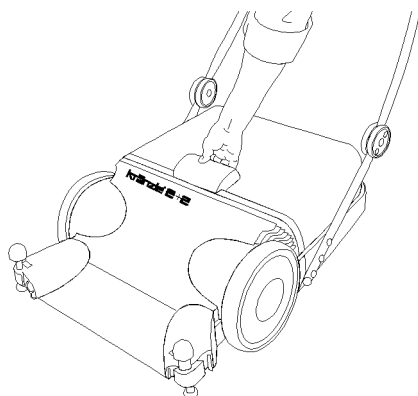

Grip the collector handle...

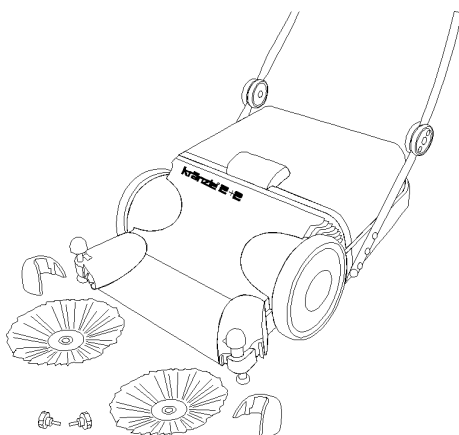

...and place the accessories on the ground

# Assembly of side brushes and push handle

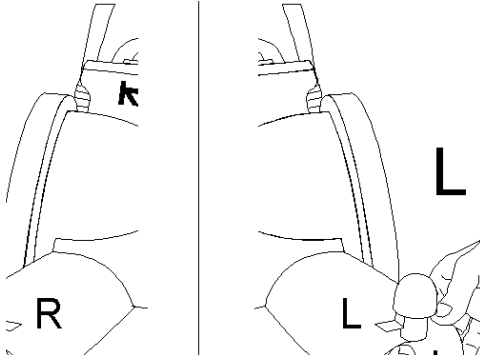

Now press the safety caps from above, making sure that they are attached to the correct sides (engraved right and left).

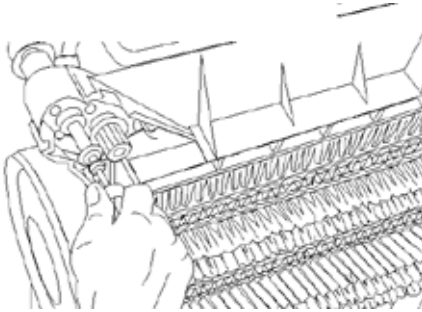

Fold back the handle on the machine. Now put the sweeper upside down on the ground and, remove the screw from the brass axle of the inlet brush.

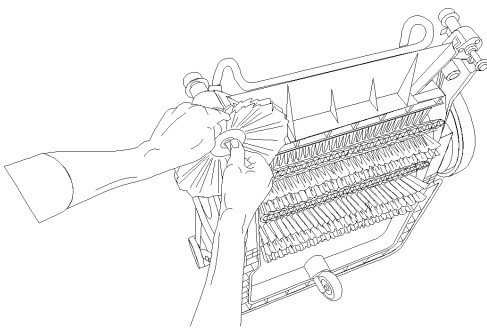

First place washer no. 72 on side brush no. 74 above the ball bearing and place both on bearing bolt A. Tighten the screw with safety washers no. 76 and no. 77 into the bolt.

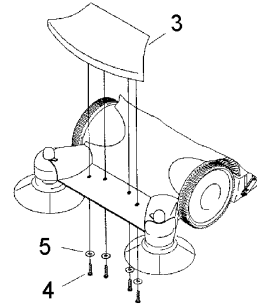

Loosen the four plastic screws (4) on the underside of the dust spoiler (3) and place the screws with the plain washer (5) on the ground.

Press the spoiler from the top onto the housing. Now turn the screws with the plain washer from below through the holes in the housing into the spoiler. Now tighten the screws.

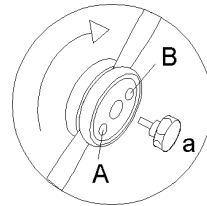

Fix the push bar into the work position in hole (A) using the star screws provided (a).

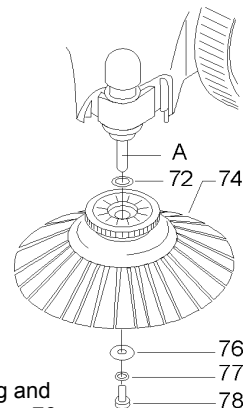

# Description

## To empty the container

When the dirt container is full, take hold of the handle and simply pull it upwards. The contents can then be disposed of accordingly. Replace the container in the reverse order.

## Loading brushes

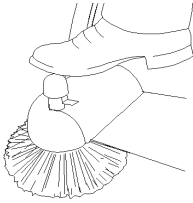

Fig. 1

Press the two brush heads to put the inlet brushes into the work position. The height of the side brushes can be adjusted on both sides.

## Unloading the brushes

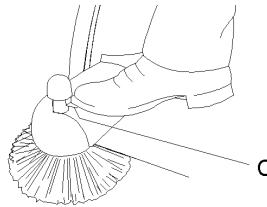
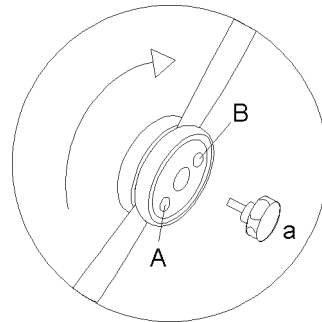
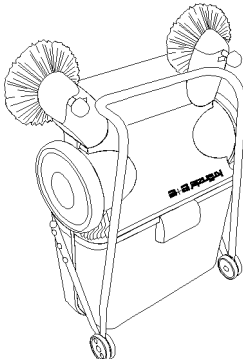

Fig. 2

When the inlet brushes are no longer required, press the release lever briefly and the brushes will engage in the rest position.

## Storage

To release the constant pressure from the side brushes, it is recommended after each use to move the machine approx. 5 cm backwards, in order to relieve the bristles and to raise the side brushes using the lever (c) (fig. 2). This prevents the bristles from deforming and diminishing their cleaning efficiency.



To release strain on the bristles of the sweeping rollers and to save space in storage, you can unscrew the star screws (a) on the left and right of the push bar, fold the bar forwards into the parking position and replace the screw in hole B. The machine can now be stored vertically and requires less space. The container does not need to be emptied to do this.

# Servicing

No work need to be done on the machine because it does not require servicing. However, you should check after each use that there are no threads, wire or strips of material round the roller. If there are any, they should be removed immediately since it will otherwise be impossible for the machine to operate properly.

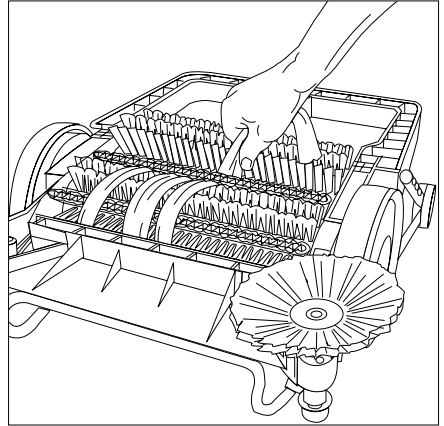

In the event of heavy soiling, grasp the dust filters (left and right) behind the cassette using the screw driver, lift them out completely and either clean the filter or replace it.

Filter paper:  
Art.-no. 50.130

---

Repair set:  
filter cassette complete:  
Art.-no. 50.190

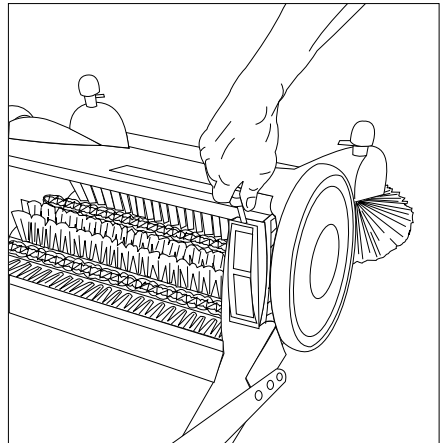

## Warranty

This warranty covers material and/or workmanship related defects only and does not extend to ordinary wear.

Machine must be operated according to enclosed operating instructions which are part of present warranty conditions.

All products sold directly to private customers are warranted for a period of 24 months, whereas the warranty period for industrial purchases is limited to 12 months.

In case of any warranty claims, please have your HP cleaner together with accessories and your purchase document ready and contact your nearest dealer or authorized service point which can also be looked up in the internet at [www.kraenzle.com](http://www.kraenzle.com) .

# Servicing

When the rollers are worn, the sweeper can be placed approx. 1 - 1,5 mm lower by removing the two washers no. 13 (see page 10).

Important:

One washer no. 13 must always be kept under the screwhead to avoid damaging to the plastic frame

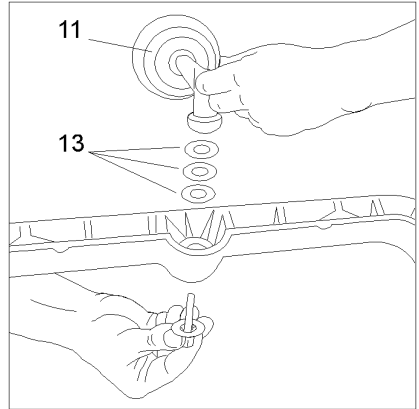

Easy replacement of brush rollers:

- 1) Put the machine upright on the joints of the folded-in push bar and the frame.
- 2) Turn the brush roller until the two screws no. 34 on the left and right side respectively are visible (see page 12) and remove these 4 screws.
- 3) Turn the brush rollers another half-turn and remove them by pulling them out.
- 4) Fit the new rollers in the reverse order.

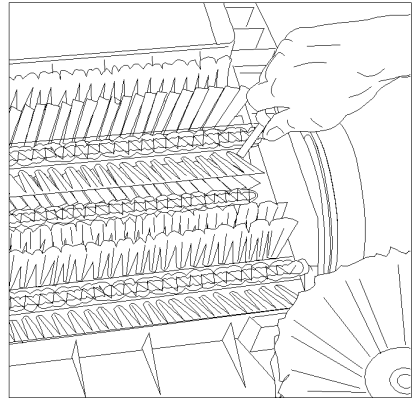

# Complete machine

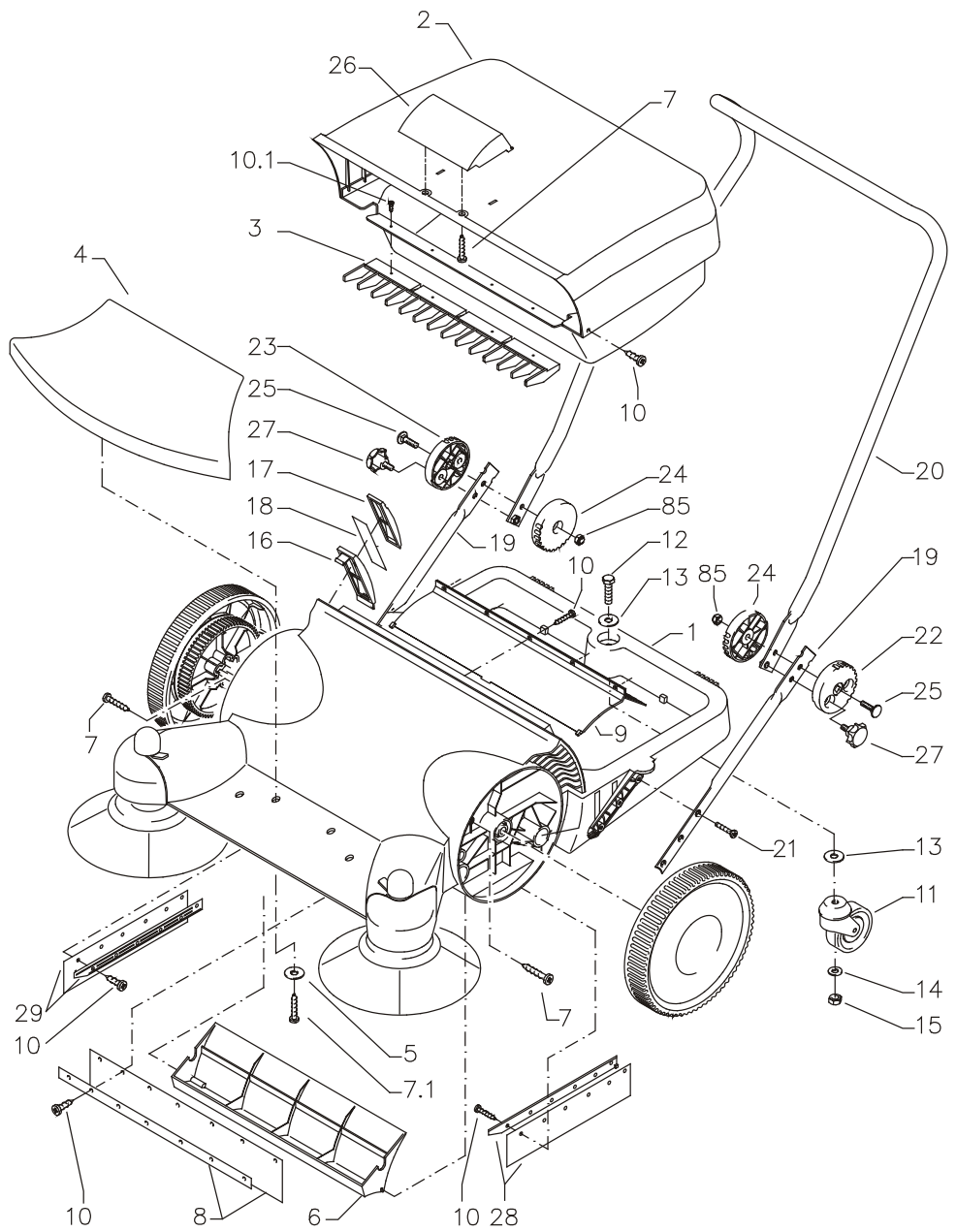



# Kränzle Power Sweeper 2 + 2

## Spare parts list Power Sweeper 2 + 2 Complete machine

Pos.	Description	Qty.	Part no.
1	Gehäuse	1	50.102
2	Schmutzbehälter	1	50.101
3	Rechen	1	50.151
4	Abdeckung vorn	1	50.150
5	Unterlegscheibe 5,3	4	50.152
6	Abweisleiste	1	50.105
7	Schraube 5,0 x 25	2	41.414 1
7.1	Kunststoffschraube 5,0 x 20	4	43.018
8	Gummilappen hinten mit Klemmleiste	1	50.171
9	Schmutzführung	1	50.163
10	Schraube 3,5 x 9,5	28	41.088
10.1	Schraube 4,8 x 13	4	44.112
11	Lenkrolle	1	50.164
12	Sechskantschraube M 10 x 45	1	50.180
13	Scheibe 10,5 DIN 9021	2	50.182
14	Scheibe 10,5 DIN 125	1	40.138
15	Elastic-Stop-Mutter M 10	1	40.139
16	Rahmen für Filter	2	50.128
17	Halterahmen für Filter	2	50.129
18	Filterpapier	2	50.130
19	Bügel unten	2	50.140
20	Schubbügel	1	50.141
21	Kunststoffschraube 6,0 x 30	6	43.423
22	Gelenkschale außen links	1	50.142
23	Gelenkschale außen rechts	1	50.143
24	Gelenkschale innen (f. links und rechts)	2	50.144
25	Schloßschraube M 8 x 30	2	50.199
26	Griff für Schmutzbehälter	1	50.177
27	Sterngriff M8	2	50.168
28	Gummilappen links mit Klemmleiste	1	50.145
29	Gummilappen rechts mit Klemmleiste	1	50.147
85	Elastic-Stop-Mutter M 8	2	41.410

### Repair set:

**Filter cassette, complete**

**50.190**

Pos. 16; Pos. 17; Pos. 18

# Left wheel and sweep rollers

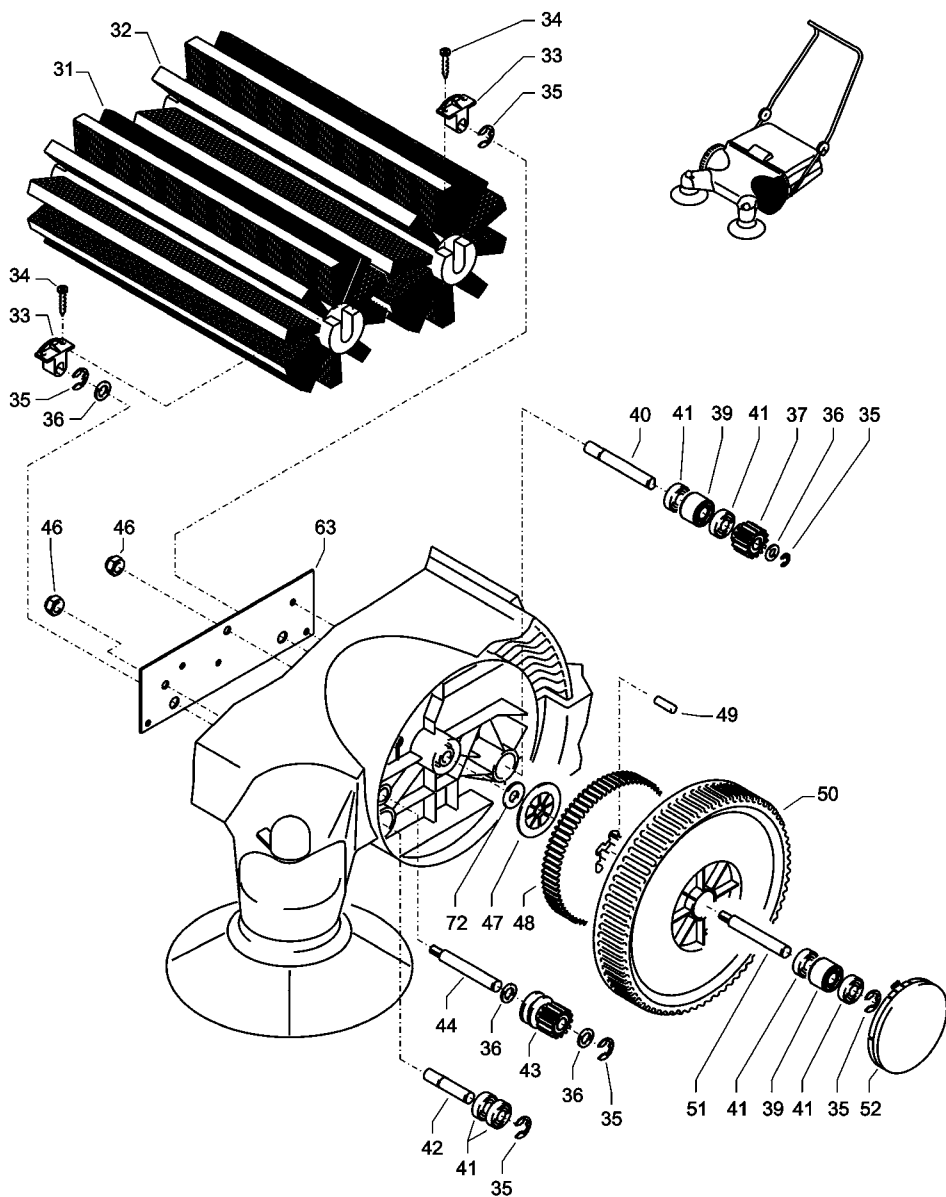

# Kränzle Power Sweeper 2 + 2

## Spare parts list Power Sweeper 2 + 2 Left wheel and sweep rollers

Pos.	Description	Qty.	Part no.
31	Bürstenwalze vorn	1	50.119
32	Bürstenwalze hinten	1	50.120
33	Bürstenmitname	2	50.121
34	Holzschraube 3,5 x 17	4	50.165
35	Sicherungsscheibe 10	6	50.133
36	Scheibe 13 DIN 433	4	50.184
37	Zahnrad z=14	1	50.115
39	Abstandshülse 20,5 mm	2	50.155 2
40	Mitnahmebolzen (links hinten)	1	50.126
41	Rillenkugellager 12 / 28 / 8	6	50.156
42	Loslagerbolzen (links unten)	1	50.122
43	Zahnrad Z=14 mit Keil (lang)	1	50.116
44	Bolzen für Seitenbesenantr. (links oben)	1	50.124
46	Elastic-Stop-Mutter M8 x 1	2	14.152
47	Scheibe	1	50.113
48	Zahnrad links z=79	1	50.109
49	Mitnahme	6	50.111
50	Rad mit Lagerung	1	50.191
51	Achse	1	50.112
52	Radkappe	1	50.108
63	Stahlversteifung	1	50.167
72	MS-Scheibe 12 x 24 x 4	1	50.149

### Repair sets:

**Brush roller, front, complete** **50.192**

Pos. 31, 2 +Pos. 33, 4 +Pos. 34

**Brush roller, rear, complete** **50.193**

Pos. 32, 2 +Pos. 33, 4 +Pos. 34

**Cog set „left“** **50.196**

3 +Pos. 35, 2 +Pos. 36, Pos. 37, Pos. 43, Pos. 47

Pos. 48, 6 +Pos. 49, 2 +Pos. 53, Pos. 72,

# Right wheel

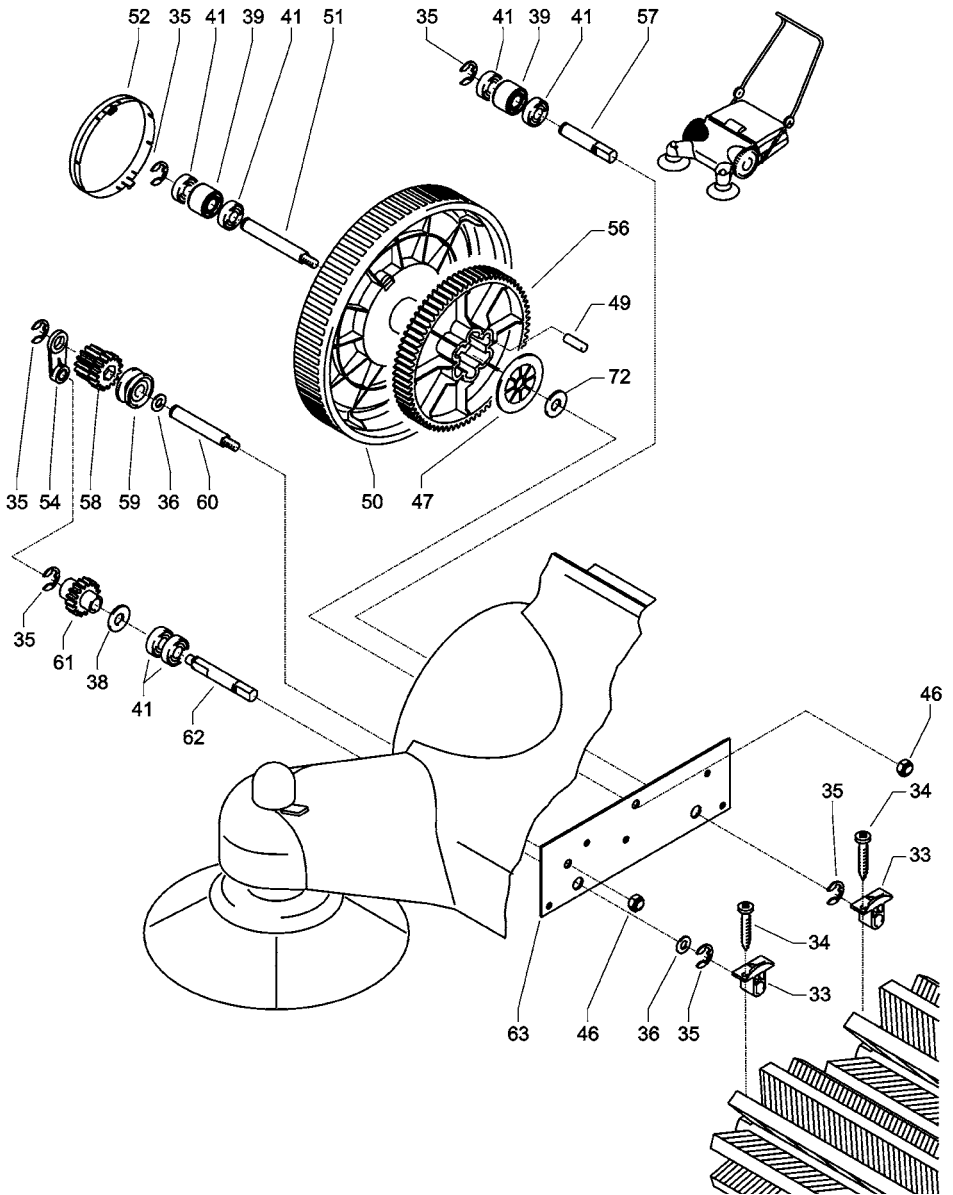

# Kränzle Power Sweeper 2 + 2

## Spare parts list Power Sweeper 2 + 2 Right wheel

Pos.	Description	Qty.	Part no.
33	Bürstenmitname	2	50.121
34	Holzschraube 3,5 x 17	4	50.165
35	Sicherungsscheibe 10	6	50.133
36	Scheibe 13 DIN 433	2	50.184
38	MS-Scheibe 12 x 24 x 2,5	1	50.139
39	Abstandshülse 20,5 mm	2	50.155 2
41	Rillenkugellager 12 / 28 / 8	6	50.156
46	Elastic-Stop-Mutter M8 x 1	2	14.152
47	Scheibe	1	50.113
49	Mitnahme	6	50.111
50	Rad mit Lagerung	1	50.191
51	Achse	1	50.112
52	Radkappe	1	50.108
54	Gegenlagerung zahnradgetriebe	1	50.161
56	Zahnrad rechts z=79	1	50.110
57	Loslagerbolzen (rechts hinten)	1	50.125
58	Doppelzahnrad	1	50.118
59	Aufsteckriemenscheibe	1	50.114
60	Bolzen für Seitenbesenantr. (rechts oben)	1	50.179
61	Zahnrad z=16	1	50.117
62	Mitnahmebolzen ( rechts unten)	1	50.123
63	Stahlversteifung	1	50.167
72	MS-Scheibe 12 x 24 x 4	1	50.149

### Repair sets:

#### **Cog set „right“**

**50.197**

3x Pos. 35, 3x Pos. 36, Pos. 47,  
6x Pos. 49, Pos. 53, Pos. 56, Pos. 58,  
Pos. 59, Pos. 61, Pos. 72,

# Left side brush

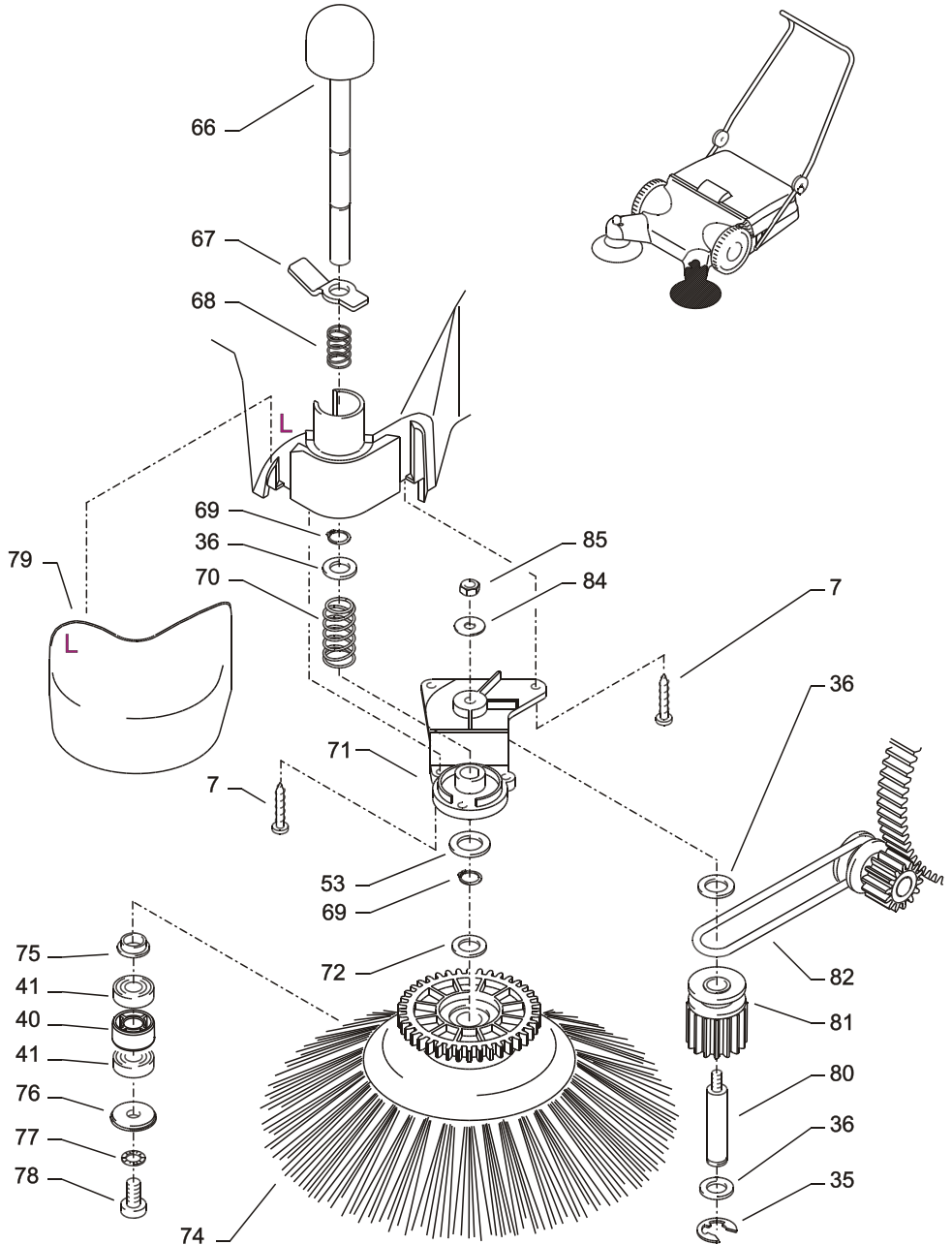

# Kränzle Power Sweeper 2 + 2

## Spare parts list Power Sweeper 2 + 2 Left side brush

Pos.	Description	Qty.	Part no.
7	Schraube 5,0 x 25	5	41.414 1
35	Sicherungsscheibe 10	6	50.133
36	Scheibe 13 DIN 433	6	50.184
40	Abstandshülse 14,5 mm	1	50.155 1
41	Rillenkugellager 12 / 28 / 8	2	50.156
53	MS-Scheibe 12 x 24 x 2,5	3	50.139
66	Rastknopf	1	50.132
67	Fußraster	1	50.131
68	Druckfeder (klein)	1	50.158
69	Sicherungsring 12 DIN 471	2	50.137
70	Rückstellfeder (groß)	1	50.159
71	Deckel für Seitenbesen	1	50.134
72	MS-Scheibe 12 x 24 x 4	1	50.149
74	Seitenbesen	1	50.136
75	Büchse	1	50.153
76	Unterlegscheibe für Seitenbesen	1	50.154
77	Sicherungsring 8,4	1	40.054
78	Schraube M8 x 16	1	50.138
79	Kunststoffabdeckung links	1	50.103
80	Bolzen für Antriebszahnrad	1	50.198
81	Zahnrad Z=14 mit Keil (kurz)	1	50.127
82	Rundriemen	1	50.160
84	Scheibe 6,4 DIN 9021	1	50.174
85	Elastic-Stop-Mutter M6	1	14.152 1

### Repair sets:

#### Side brush drive, complete

**50.194**

Pos. 35, Pos. 36, Pos. 81, Pos. 82,

#### Side brush, complete

**50.195**

Pos. 39, Pos.72, Pos. 74, Pos. 75

Pos. 76, Pos. 77, Pos. 78

# Right side brush

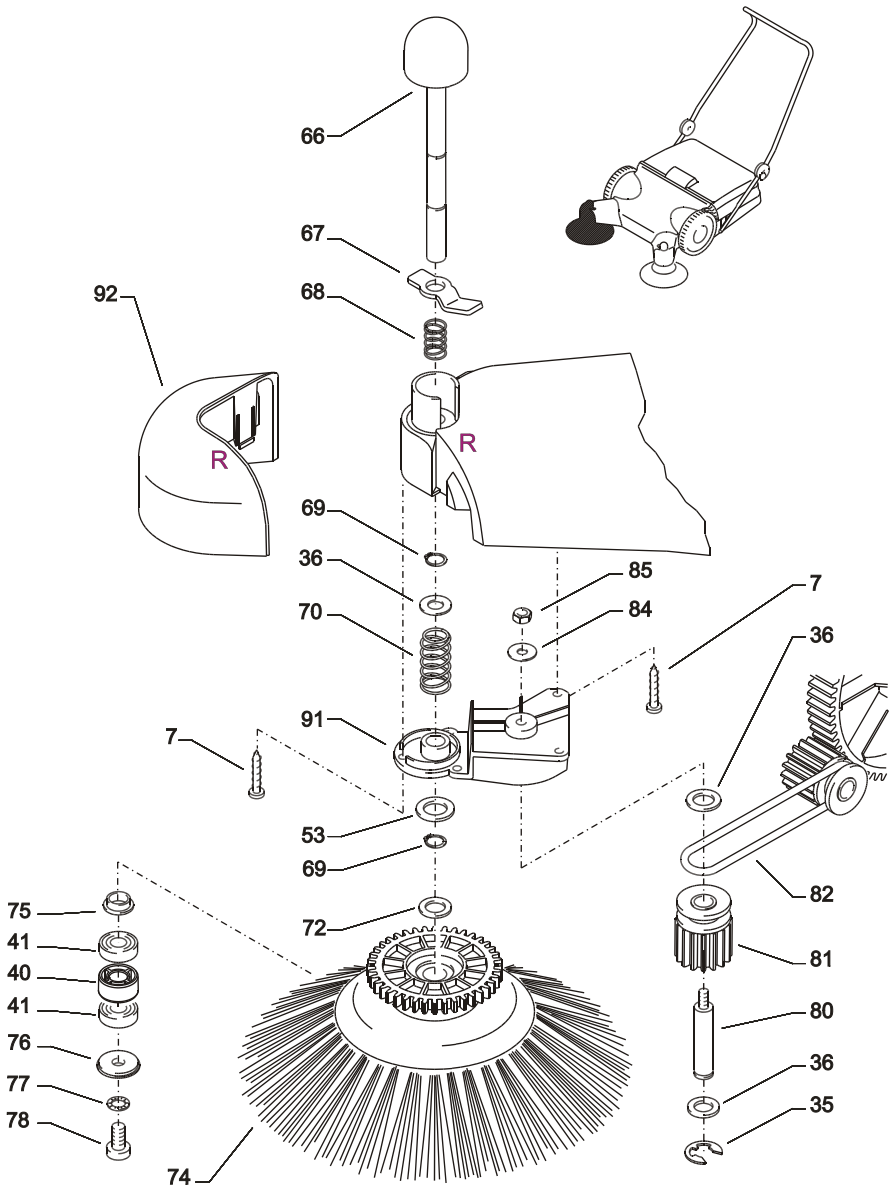



# Kränzle Power Sweeper 2 + 2

## Spare parts list Power Sweeper 2 + 2 Right side brush

Pos.	Description	Qty.	Part no.
7	Schraube 5,0 x 25	5	41.414 1
35	Sicherungsscheibe 10	6	50.133
36	Scheibe 13 DIN 433	6	50.184
40	Abstandshülse 14,5 mm	1	50.155 1
41	Rillenkugellager 12 / 28 / 8	2	50.156
53	MS-Scheibe 12 x 24 x 2,5	3	50.139
66	Rastknopf	1	50.132
67	Fußraster	1	50.131
68	Druckfeder (klein)	1	50.158
69	Sicherungsring 12 DIN 471	2	50.137
70	Rückstellfeder (groß)	1	50.159
72	MS-Scheibe 12 x 24 x 4	1	50.149
74	Seitenbesen	1	50.136
75	Büchse	1	50.153
76	Unterlegscheibe für Seitenbesen	1	50.154
77	Sicherungsring 8,4	1	40.054
78	Schraube M8 x 16	1	50.138
80	Bolzen für Antriebszahnrad	1	50.198
81	Zahnrad Z=14 mit Keil (kurz)	1	50.127
82	Rundriemen	1	50.160
84	Scheibe 6,4	1	50.174
85	Elastic-Stop-Mutter M6	1	14.152 1
91	Deckel für Seitenbesen rechts	1	50.135
92	Kunststoffabdeckung rechts	1	50.104

### Repair sets:

#### Side brush drive, complete

**50.194**

Pos. 35, Pos. 36, Pos. 81, Pos. 82,

#### Side brush, complete

**50.195**

Pos. 39, Pos. 72, Pos. 74, Pos. 75

Pos. 76, Pos. 77, Pos. 78

# Notes

# Notes

